

CUNNANE STRATTON REYNOLDS
LAND PLANNING & DESIGN

Student Village, Cork Road, Waterford
Conceptual Landscape Design Rationale

PROJECT NO. 22338

FEBRUARY 2024



Development Plan Review	Page 2
Spatial Arrangement	Page 3
Concept Sketch: Phase 1	Page 4
Concept: Inspiring Images	Page 5
Concept: Masterplan	Page 6
Concept: Surface Materials	Page 7
Concept: Courtyard	Page 8
Concept: Recreation & Amenity Spaces	Page 9
Concept: Greenway Connections	Page 10
Concept: Soft Landscape	Page 11
Concept: Biodiversity and Pollinator Planting	Page 12
Concept: The Edible Landscape	Page 13
Concept: Sustainable Drainage Systems (SuDS)	Page 14
Landscape Concept: Select Planting Palette	Page 15
Maintenance and Management	Page 16

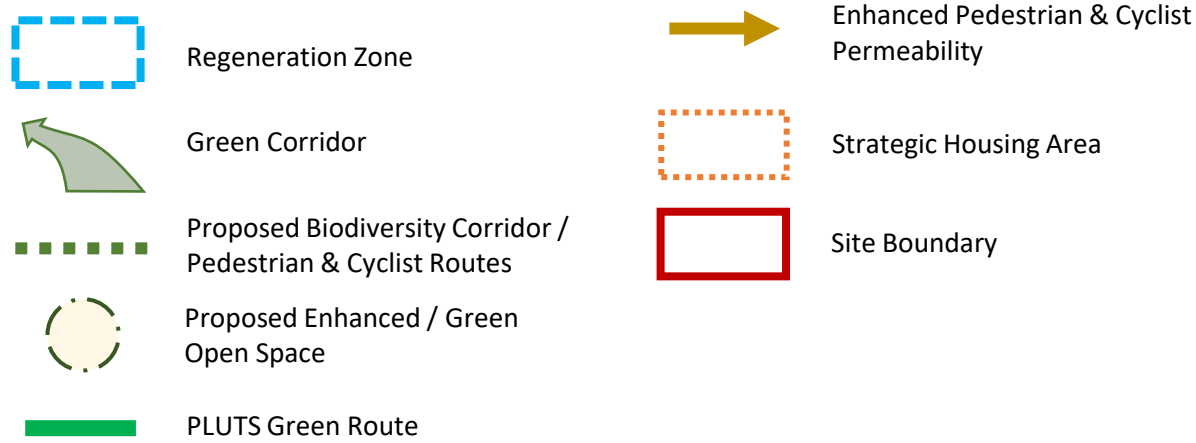

Development Plan Review

Constraints and Opportunities

- Habitat creation
- Pollinator friendly landscaping schemes
- Nesting boxes for pollinators, birds and mammals
- Promote retention and creation of open drainage ditches
- Promote integration of SuDS in design concept
- Develop and enhance safe and easy pedestrian and cyclist access to Waterford Nature Park, Kilbarry Park and the RSC
- Create Streetscape, enclosure and sense of place
- Quality public realm to provide area with own individual identity
- Planting and boundary treatment to maximise privacy
- Parameters of placemaking: Places should be:
 - Accessible and connected
 - Comfortable, well designed and safe
 - Green sustainable, attractive and multifunctional
 - Social and inclusive

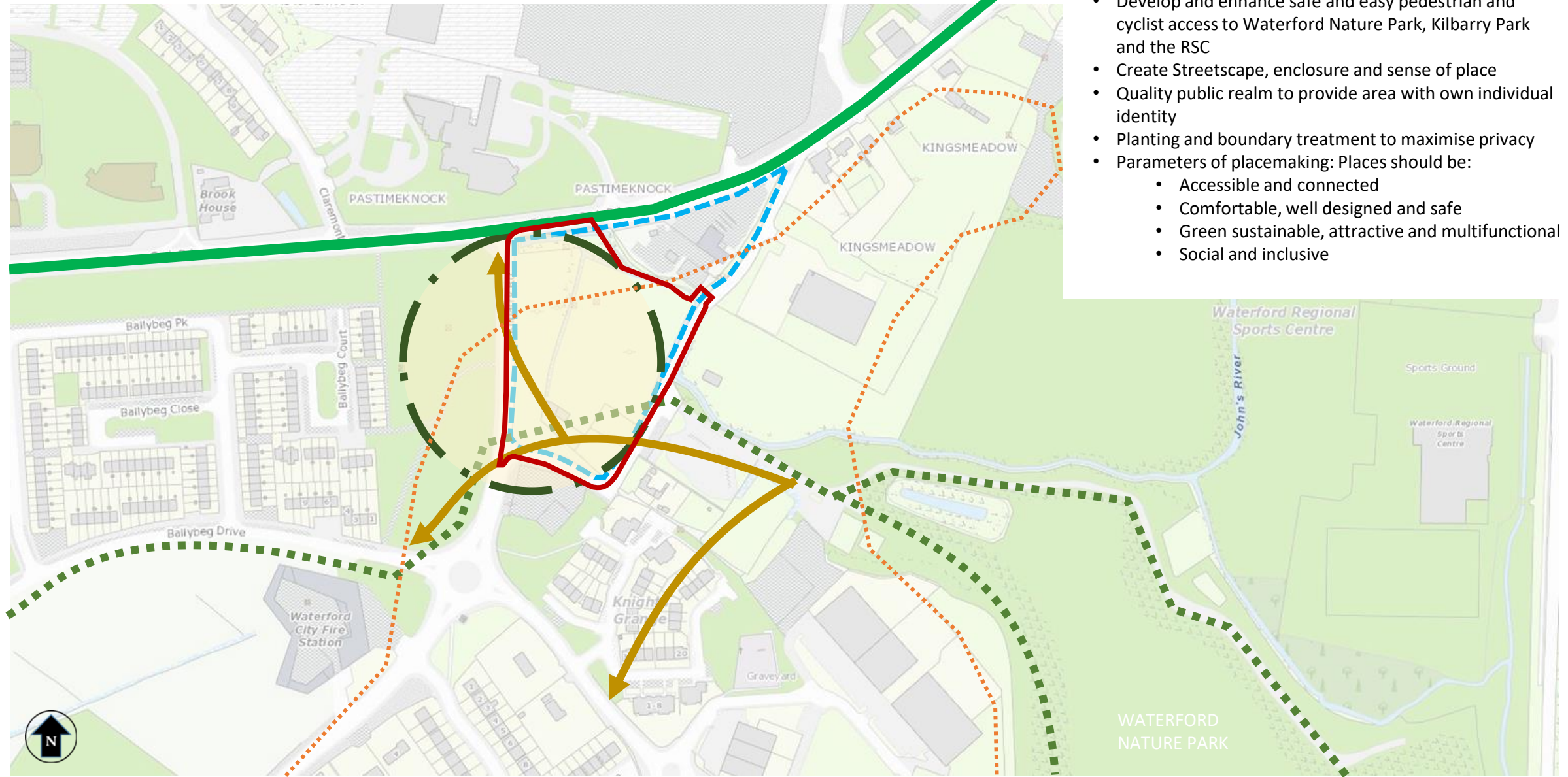

Concept : Spatial Arrangement



Legend

- 1 Public Plaza
- 2 Multifunctional Spaces
- 3 Greenway plaza
- Pedestrian Connectivity
- Main Site Access
- Entrance to Courtyard



Concept Sketch: Phase 1

LAND PLANNING & DESIGN

Design Inspiration

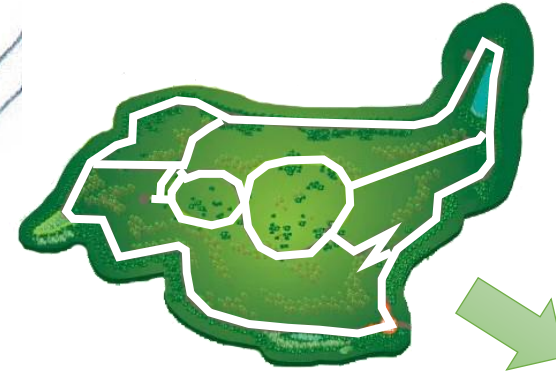

Waterford Nature Park



Pine Tree



Bark Texture & Pattern

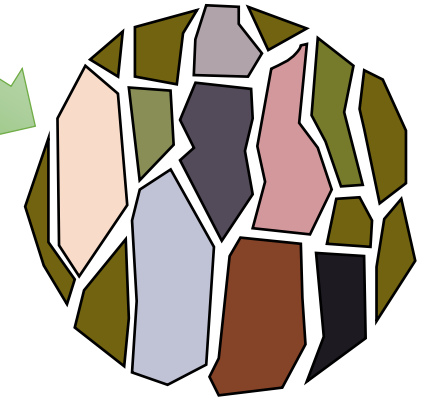



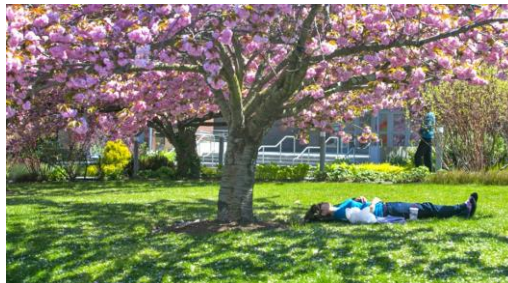





























Concept: Inspiring Images



Concept: Masterplan

Legend

-  OPEN SPACE TREES
-  NATIVE TREES
-  TALL POLLINATOR SHRUBS
-  PUBLIC AMENITY GRASS
-  MEADOW
-  POLLINATOR SHRUB AND GROUNDCOVER PLANTING
-  ARTIFICIAL GRASS
-  RETENTION POND PLANTING
(Planting proposal in coordination with ecologist)
-  RIPARIAN ZONE
(Please refer to ecologist's habitat map)
-  POLLINATOR HEDGE
-  NATIVE HEDGE
-  TARMAC
-  HOT ROLLED ASPHALT
Buff colour, to withstand occasional vehicle access
-  PERMEABLE CONCRETE BLOCK PAVING
Brown/Pink & Natural colours, 240x120x80mm
-  PERMEABLE PLAZA SURFACE
Concrete pavers, graphite & silver colours, 200x100x80mm
-  CAST IN-SITU CONCRETE SURFACE
To withstand occasional vehicle access
-  RAISED TABLE
Concrete setts, brown/pink colour, mix size x 80(d)mm
-  FEATURE PAVING
Concrete pavers, graphite & silver colour, 300x150x100mm
-  CONCRETE PAVING
Natural colour, 200x100x80mm, to withstand occasional vehicle access
-  SELF COMPACTING GRAVEL
Ballylusk or similar
-  GREEN LINK
Tar and buff chip
-  STEPPING STONES
-  SEATING
-  CITY BIKE PARKING
-  OUTDOOR GYM
-  TABLE TENNIS AND SWING
-  OUTDOOR CHESS GAME
Concrete slabs, silver and charcoal colour, 400x400mmx80mm
-  RAISED PLANTER
-  COVERED BICYCLE SHELTER
-  BICYCLE RACK
-  FENCE
-  GABION RETAINING WALL
-  WAYLEAVE
- EXISTING STREAM
- PUBLIC LIGHTING
- SITE BOUNDARY



LAND PLANNING & DESIGN

Concept: Surface Materials

North plaza



Plaza: Permeable Concrete Pavers 200x100x80 Graphite & Silver colours

Western Entrance & Parking



Parking: Permeable concrete block paving Brown/Pink & Natural colours. 240x120x80



Raised Table: Concrete Setts, Brown/Pink colour, mix size x80(d)



Footpath to Building Edge: Concrete pavers Graphite and Silver colour, 300x150x100

Central Courtyard



Cast In-situ Concrete Surface



Buff-colour Asphalt



Concrete Paving, Natural colour, 200x100x80





































Ballylusk self-compacting gravel

All materials will be designed to a high standard, be robust and withstand a long life, as well as meet the CE standard.

Concept: Courtyard



Legend

-  OPEN SPACE TREES
-  NATIVE TREES
-  TALL POLLINATOR SHRUBS
-  PUBLIC AMENITY GRASS
-  MEADOW
-  POLLINATOR SHRUB AND GROUNDCOVER PLANTING
-  ARTIFICIAL GRASS
-  RETENTION POND PLANTING
(Planting proposal in coordination with ecologist)
-  RIPARIAN ZONE
(Please refer to ecologist's habitat map)
-  POLLINATOR HEDGE
-  NATIVE HEDGE
-  TARMAC
-  HOT ROLLED ASPHALT
Buff colour, to withstand occasional vehicle access
-  PERMEABLE CONCRETE BLOCK PAVING
Brown/Pink & Natural colours, 240x120x80mm
-  PERMEABLE PLAZA SURFACE
Concrete pavers, graphite & silver colours, 200x100x80mm
-  CAST IN-SITU CONCRTE SURFACE
To withstand occasional vehicle access
-  RAISED TABLE
Concrete setts, brown/pink colour, mix size x 80(d)mm
-  FEATURE PAVING
Concrete pavers, graphite & silver colour, 300x150x100mm
-  CONCRETE PAVING
Natural colour, 200x100x80mm, to withstand occasional vehicle access
-  SELF COMPACTING GRAVEL
Ballylusk or similar
- GREEN LINK
Tar and buff chip
-  STEPPING STONES
-  SEATING
-  CITY BIKE PARKING
-  OUTDOOR GYM
-  TABLE TENNIS AND SWING
-  OUTDOOR CHESS GAME
Concrete slabs, silver and charcoal colour, 400x400mmx80mm
-  RAISED PLANTER
-  COVERED BICYCLE SHELTER
-  BICYCLE RACK
-  FENCE
-  GABION RETAINING WALL
-  WAYLEAVE
-  EXISTING STREAM
-  PUBLIC LIGHTING
-  SITE BOUNDARY

Concept: Recreation & Amenity Spaces

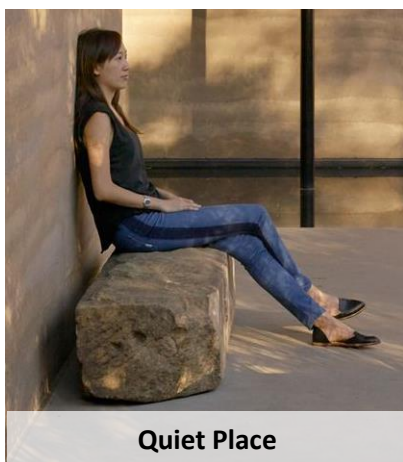
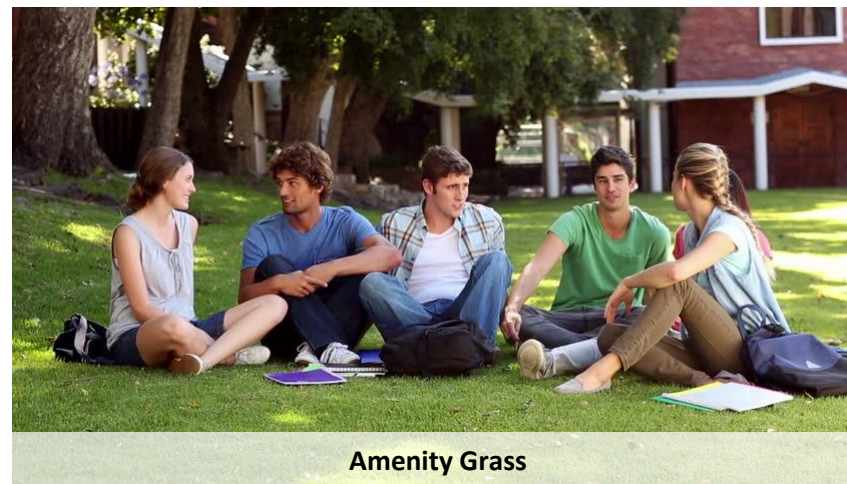
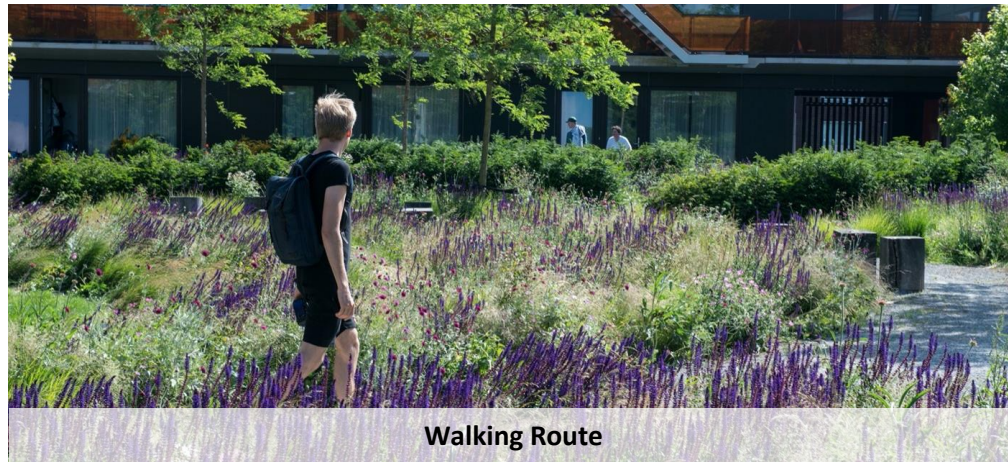

Concept: Greenway Connections

LAND PLANNING & DESIGN



Concept: Soft Landscape

Planting selection to be in line with local native species and the All-Ireland Pollinator Plan



Seasonality



Place Making

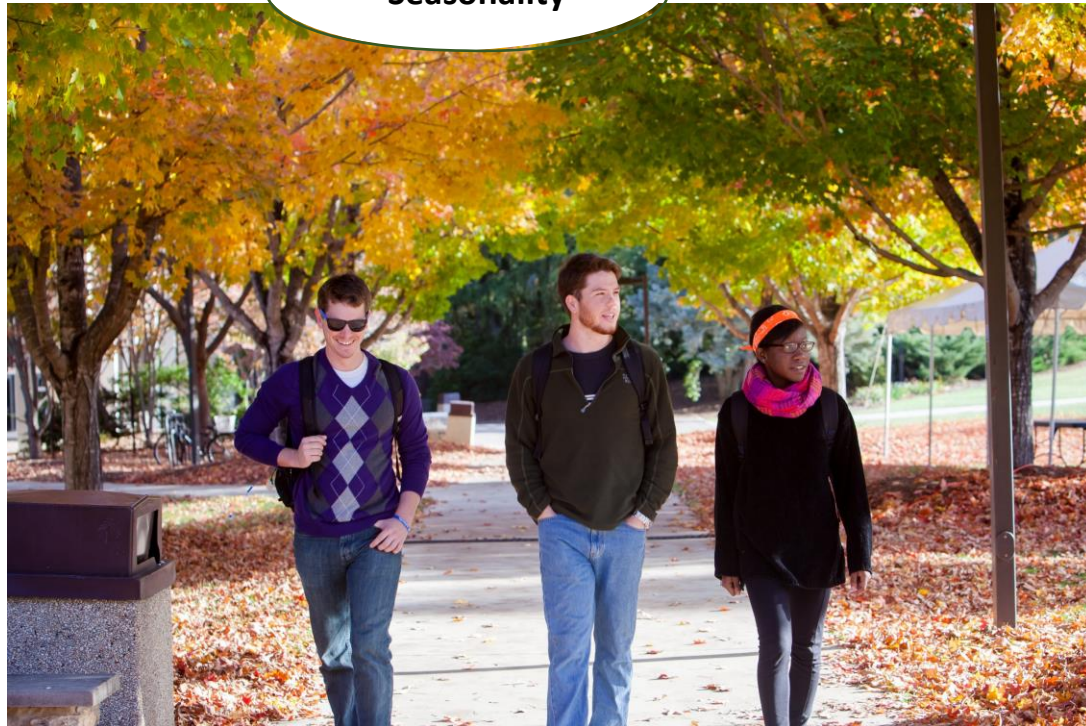

Concept: Biodiversity and Pollinator Planting

Typically the Pollinator Planting Strategy aims to:

- provide a pollinator friendly environment.
- Maximizing the use of native species
- use of diverse combinations of flowering plants.
- provide extended flowering through the seasons with extended opportunity for the supply of nectar and pollen.
- provide information on the importance of pollinators and raise awareness of their role in our ecosystems



Pollinator Planting



Native Tree Species



Differential Mowing Regime

Concept: The Edible Landscape

The integration of fruiting trees and shrubs together with nuts and edible herbs for foraging within the overall planting scheme may provide a welcome addition to the diet of some students and help minimise food poverty even just a little bit.

Species for suitable inclusion within the scheme may include:

- Corylus sp.
- Malus domestica
- Pyrus communis
- Prunus domestica
- Castanea sativa
- Sambucus nigra
- Ribes nigrum
- Ribes uva-crispa
- Rosa sp.
- Vitis sp.



Concept: Sustainable Drainage Systems (SuDS)

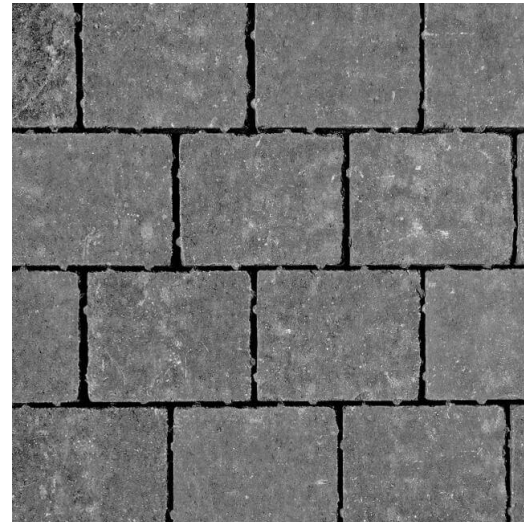

Sustainable Drainage Systems (SuDS) are designed to maximise the opportunities and benefits we can secure from surface water management by managing rainwater close to where it falls. Some types of SuDS include planting, others include proprietary products.

SuDS can improve the quality of life in developments and urban spaces by making them more vibrant, visually attractive, sustainable and more resilient to change, by improving urban air quality, regulating building temperatures, reducing noise and delivering recreation and education opportunities.

Examples of SuDS include:

- Swales, detention basins, ponds and wetlands
- Permeable pavements
- Trees capture rainwater and provide evapotranspiration, biodiversity and shade
- Soakaways and infiltration basins
- Bioretention systems, including rain gardens, collect runoff, allowing it to pond temporarily on the surface before filtering through vegetation and underlying soils.
- Rainwater harvesting systems

SuDS can be applied anywhere including open spaces, developments, parking areas, streets, parks etc and measures for incorporating these throughout the subject site.

Planting Schedule

Note: Planting selection in line with local native species and the All-Ireland Pollinator Plan

NATIVE AND POLLINATOR OPEN SPACE TREES - including fruit and nut trees	Height / girth
Amelanchier x grandiflora 'Robin Hill'	16-18cm gth. RB
Corylus avellana	16-18cm gth. RB
Malus domestica	16-18cm gth. RB
Prunus domestica	16-18cm gth. RB
Pyrus calleryana 'Chanticleer'	16-18cm gth. RB
Pyrus communis	16-18cm gth. RB
Castanea sativa	16-18cm gth. RB
NATIVE TREES - to be under-planted with bulbs	Height / girth
Quercus petraea	16-18cm gth. RB
Betula pendula	16-18cm gth. RB
Sorbus aria	16-18cm gth. RB
Sorbus aucuparia	16-18cm gth. RB
Prunus avium	16-18cm gth. RB
Prunus padus	16-18cm gth. RB
Alnus glutinosa	16-18cm gth. RB
Pinus sylvestris	120-150cm, RB
NATIVE HEDGEROW TRANSPLANT MIX planted 3/m	Height / girth
Crataegus monogyna	60-90cm high, BR
Corylus avellana	60-90cm high, BR
Prunus spinosa	60-90cm high, BR
Viburnum opulus	60-90cm high, BR
Ilex aquifolium	60-90cm high, BR
Euonymus europaeus	60-90cm high, BR
Rosa canina	60-90cm high, BR
NATIVE AND POLLINATOR ORNAMENTAL HEDGE @ 3/m	Size
Brachyglottis 'Sunshine'	60-90cm, CG
Elaeagnus pungens 'Maculata'	60-90cm, CG
Ligustrum ovalifolium	60-90cm high, BR
Rosa canina	60-90cm high, BR
Sarcococca confusa	60-90cm, CG
Viburnum opulus	60-90cm high, BR
Viburnum tinus 'Eve Price'	60-90cm, CG



POLLINATOR SHRUB AND GROUND COVER PLANTING- plant in groups of same species ranging from min. 5-15no. @5/m2	Size
Rosmarinus officinalis	3L, PG
Hebe sp.	3L, PG
Prunus tenella	3L, PG
Potentilla fruticosa	3L, PG
Skimmia japonica	3L, PG
Lavandula angustifolia 'Hidcote'	3L, PG
Stachys byzantina	3L, PG
Erysimum 'Bowles's Mauve'	3L, PG
Berberis darwinii	3L, PG
Bergenia 'Eroica'	3L, PG
Rosmarinus officinalis	3L, PG
Cotoneaster conspicuus	3L, PG
Elaeagnus angustifolia	3L, PG
Jasminum nudiflorum	3L, PG
Hedera colchica 'Dentata Variegata'	3L, PG
Lonicera x purpusii 'Winter Beauty'	3L, PG
Cotoneaster conspicuus	3L, PG
Mahonia repens	3L, PG
EDIBLE SHRUBS	Size
Ribes nigrum	5L, PG
Ribes uva-crispa	5L, PG
Rosa sp.	5L, PG
Vitis sp.	5L, PG
RETENTION POND PLANTING – proposal coordinated with ecologist, plant in groups of same species ranging from min. 5-15no. @10/m2	Size
Carex paniculata	2L, PG
Juncus articulatus	2L, PG
Juncus conglomeratus	2L, PG
Juncus inflexus	2L, PG
Lythrum salicaria	2L, PG
Phragmites australis	2L, PG
BULBS & PERENNIALS MIX- plant in drifts	Size
Typical species will include:	
Anemone nemorosa, Geranium robertianum, Hyacinthoides non-scripta, Muscari 'Blue Spike', Oxalis acetosella, Primula vulgaris, Viola riviniana, Colchicum sp., Crocus sp., Galanthus nivalis, Salvia sp., Anemone x hybrida, Anemone hupehensis, Aster sp., Chrysanthemum sp., Dahlia sp., Helleborus sp., Rudbeckia 'Goldstrum' Calamagrostis 'Karl Foerster', Stipa 'Ponytails'	bulbs, corms, & p9's

Landscape Concept:
Select Planting Palette

ALL-IRELAND POLLINATOR PLAN WILDFLOWER MIXTURE - sow @ 1.5g/m, seed mix to be native sourced irish seed	Size
Species List:	
Birdsfoot Trefoil, Black Meddock, Cowslip, Devil's Bit Scabious, Meadow Buttercup, Field Scabious, Hemp Agrimony, Kidney Vetch, Lady's Bedstraw, Lady's Ann lace, Lesser Knapweed, Meadowsweet, Mullein, Ox-eye Daisy, Purple Loosestrife, Ragged Robin, Red Campion, Red Clover, Ribwort Plantain, Rough Hawksbit, Sorrel, St Johnswort, Wild Angelica, Wild Carrot, Yarrow, Yellow Agrimony, Yellow Rattle, Teasel and more.	Seed mix
Also includes 35% annuals: Corn Marigold, Corn Poppy, Corncockle, Cornflower, Scented Mayweed	



Crataegus monogyna



Sorbus aucuparia

LAND PLANNING & DESIGN

Maintenance & Management

INTRODUCTION

This document sets out the proposed maintenance and management plans for the establishment and ongoing maintenance of the landscape element of the proposed development. There will be a minimum 18 months defects period on all soft landscape works implemented. Thereafter the landscaping will be maintained in perpetuity consecutive 12 months periods.

1.0 SOFT LANDSCAPE WORKS SPECIFICATIONS

1.1 Site Clearance Generally

- General: Remove rubbish, concrete, metal, glass, decayed vegetation and contaminated topsoil.
- Stones: Remove those with any dimension exceeding 25mm.
- Contamination: Remove material containing toxins, pathogens or other extraneous substances harmful to plant, animal or human life. In accordance with current Health and safety legislation.
- Vegetation: remove all weed growth.
- Large roots: Grub up and dispose of without undue disturbance of soil and adjacent areas.

1.2 Weed Control

Remove all noxious and undesirable weeds from the sit. Weeds shall include: Ragwort, Himalayan Balsam, Giant hogweed & Japanese knotweed, Thistle, Dock, Common Barberry, Male Wild Hop and Spring Wild Oat, or any other noxious species identified by the Department of Environment. For the removal of certain species such as Japanese Knotweed a method statement is to be prepared and submitted to the Department of Environment.

1.3 Standards

In preparing the landscaping, supplying plants and maintaining the landscaping the following standards are to be adhere to:

- BS 3882 Specification for topsoil and requirements for use
- BS 3936-1 to 10 Specification for the supply of nursery stock
- NPS National Plant Specification
- BS 3998 Tree Works: Recommendations
- BS 4428 Code of Practice for general Landscape Operations
- BS 5837 Tree in relation to Construction
- BS 7370-1 to 5 Grounds Maintenance
- BS 8545 Trees: from nursery to independence in the landscape-recommendations
- BS 8601 Specification for subsoil and required use
- BS EN 1722-9 Fences Specification for mild steel - low carbon steel - fences with round or square verticals and flat horizontals

The latest publications for each document are to be used.

1.4 Soil Conditions

- Soil for cultivating and planting: Moist, friable and do not plant if waterlogged.
- Frozen or snow covered soil: Give notice before planting. Provide additional root protection. Prevent planting pit sides and bases and backfill materials from freezing.

1.5 Climatic Conditions

- General: Carry out the work while soil and weather conditions are suitable.
- Strong winds: Do not plant.

1.6 Times of year for planting

- Deciduous trees and shrubs: Late October to early March.
- Evergreens/Conifers: October/November or Feb/ March.
- Container Grown plants: Any time of years.

1.7 Mechanical Tools

Restrictions: Do not use within 100mm of tree and plant stems.

1.8 Watering

- Quantity: Wet full depth of topsoil.
- Application: Even and without damaging or displacing plants or soil.
- Frequency: As necessary to ensure establishment and continued thriving of planting.

1.9 Preparation, Planting and Mulching Materials

General: Free from toxins, pathogens or other extraneous substances harmful to plant, animal or human life.

1.10 Plants/ Trees - General

- Condition: Materially undamaged, sturdy, healthy and vigorous.
- Appearance: Of good shape and without elongated shoots.
- Hardiness: Grown in a suitable environment and hardened off.
- Health: Free from pests, diseases, discoloration, weeds and physiological disorders.
- Budded or grafted plants: Bottom worked.
- Root system and condition: Balanced with branch system.
- Species: True to name.

1.11 Container Grown Plants/ Trees

- Growing medium: With adequate nutrients for plants to thrive until permanently planted.
- Plants: Centred in containers, firmed and well watered.
- Root growth: Substantially filling containers, but not root bound, and in a condition conducive to successful transplanting.
- Hardiness: Grown in the open for at least two months before being supplied.
- Containers: With holes adequate for drainage when placed on any substrate commonly used under irrigation systems.

1.12 Labelling And Information

General: Provide each plant/ tree or group of plants/ trees of a single species or cultivar with supplier's labelling for delivery to site, showing:

- Full botanical name., Total number, Number of bundles, Part bundles.
- Supplier's name, Employer's name and project reference.
- Plant specification, in accordance with scheduled National Plant Specification categories and BS 3936.

1.13 Plant/ Tree Substitution

Plants/ trees unobtainable or known to be likely to be unobtainable at time of ordering. Submit alternatives, stating the price and difference from specified plants/ trees. Obtain approval before making any substitution.

1.14 Plant Handling, Storage Transport and Planting

- Standard: To HTA 'Handling and Establishing Landscape Plants'.
- Frost: Protect plants from frost.
- Handling: Handle plants with care. Protect from mechanical damage and do not subject to shock, e.g. by dropping from a vehicle.
- Planting: Upright or well balanced with best side to front.

1.15 Treatment of Tree Wounds

Cutting: Keep wounds as small as possible.

- Cut cleanly back to sound wood using sharp, clean tools.
- Leave branch collars. Do not cut flush with stem or trunk.
- Set cuts so that water will not collect on cut area.
- Fungicide/ Sealant: Do not apply unless instructed.

1.16 Protection of Existing Grass

- General: Protect areas affected by planting operations using boards/ tarpaulins.
- Excavated or imported material: Do not place directly on grass.

Duration: Minimum period.

1.17 Surplus Material

Subsoil, stones, debris, wrapping material, canes, ties, temporary labelling, rubbish, pruning's and other arising's: Remove.

1.18 General Planting/Seeding

- Planting shall be carried out within the contract period but not during periods of frost, drought, cold drying winds or when the soil is waterlogged, or when the moisture of the soil exceeds field capacity.
- All containers and protective coverings including biodegradable coverings to root systems shall be removed prior to planting. Roots, except for emergent vegetation, shall be teased out from the root-ball, spread evenly and not twisted.
All plant material shall be planted upright or placed so as to be well-balanced. Extreme care is to be taken to avoid damage to the root system, stem and branches when planting. The plant shall be positioned such that after planting the original soil mark on the stem is at finished ground level.
- Following completion of planting, grass seeding and turf laying, the soil over the whole of the planted, seeded or turfed area shall be sufficiently watered to achieve its field capacity.

- On completion of planting, watering and mulching, all areas shall be left tidy and weed-free and shall be maintained in a tidy and weed-free state until completion of the works.
- For shrub and transplant pit planting, notch planting and ordinary planting, the plant positions shall be set at equal centres in order to obtain a natural dense cover when mature. For notch and pit planting plants shall be planted in parallel lines. Planting positions in each row shall be staggered with the previous row.
- Finely-broken backfill material shall be carefully spread around roots and root trainers of all plants and the plants given slight shake to ensure that all interstices/ gaps are filled with soil, which shall then be consolidated by heeling. Careful filling and heeling shall continue as necessary at 150mm layers.

1.18.1 Mulching

Newly planted shrub areas shall be mulched immediately after planting to a depth of 50mm or in accordance with the details indicated on the drawing. Mulch shall be coarse chipped tree bark, composted for 2-4 months. Particle size 25-75mm diameter. No Fines.

1.18.2 After Planting & Mulching

- Watering: Immediately after planting, thoroughly and without damaging or displacing plants or soil.
- Firming: Lightly firm soil around plants and fork and/ or rake soil, without damaging roots, to a fine tilth with gentle cambers and no hollows.
- All areas shall be left tidy and weed-free and shall be maintained in a tidy and weed-free state until completion of the works.

1.19 Tree Planting

Attached in the appendix are typical tree planting details for this site.

1.19.1 Tree Pits

- Sizes: at least 300mm greater than rootball in all directions.
- Sloping ground: Maintain horizontal bases and vertical sides with no less than minimum depth throughout.
- Pit bottoms: With slightly raised centre. Break up to a depth of 100mm.
- Pit sides: Scarify.

1.19.2 Semi-Mature Trees

- Standard: Prepare roots and transplant to BS 8545.
- Planting shall be carried out by positioning the tree in the centre of the pit closely against the tree stake and spreading the tree roots to their fullest extent.
- Backfilling material: Previously prepared mixture of topsoil excavated from pit and additional compost as required.
- Immediately following planting, trees with stakes shall be secured with tree ties. Tree ties shall be fixed so that movement of the tree shall not cause damage or abrasion to the bark, top tie to be 50mm below top stake.

1.19.3 Staking Generally

Softwood, peeled chestnut, larch or pine, straight, free from projections and large or edge knots and with pointed lower end. Adjustable rubber ties to be fixed to all trees and at the correct size for the tree.

1.19.4 Mulch Circles/Squares

All existing trees/newly planted trees within open grass areas or grass verges shall have 50mm depth mulch circle/square of a maximum 1m diameter or as allowed by verge width.

1.20 Shrub Planting

- All shrubs are to be pit planted. General pit dimensions are to be wide enough to accommodate roots when fully spread and 75mm deeper than root system.
- Break up base of pit to a depth of 150 mm, incorporating soil ameliorant/ conditioner at 50 g/m².
- Pits to be backfilled with previously excavated material. Backfilling to be done in layers of 150mm depth; at each stage the filling to be firmly consolidated.
- Soil ameliorants can be premixed with the soil applied or mixed in during planting.
- Soil ameliorants to consist of an approved compost at 10L per m²; and 150g/m² of 10:10:10 NPK slow release fertilizer, or as approved.
- All shrub areas to be finished, with 75mm of medium grade bark mulch.

1.21 Hedgerow Planting

- Preparation: Dig trench to 500mm width for single staggered row, ensuing pit base is broken up 100mm deeper than plant rootball.
- Ameliorants: Compost at 10lt/m² and 10:10:10 NPK slow release fertiliser at 150g/m².
- Planting: Mix in soil ameliorants with excavated topsoil, or if there is poor topsoil then mix in with imported new topsoil. Firm down topsoil lightly in layers of 150mm by treading.
- Additional Requirements: If there is no existing fencing or barrier, install a protective fence to stop people walking through it until hedge is established. If there is livestock adjoining hedge install a stockproof fence or electrical fence 1m from hedge line until hedge is established.
- Prior to new growth cut the hedge back by 300mm to encourage new growth from base.

1.23 Removing Trees and Shrubs

- Identification: Clearly mark trees and hedges to be removed.
- Work near retained trees: Where canopies overlap, take down trees carefully in small sections to avoid damage to adjacent trees that are to be retained.

1.24 Failures of Planting

- Defects due to materials or workmanship not in accordance with the Contract: Plants/ trees/ shrubs that have failed to thrive.
 - Exclusions: Theft or malicious damage after completion.
 - Rectification: Replace with equivalent plants/ trees/ shrubs.
- Replacements: To match size of adjacent or nearby plants of same species or match original specification, whichever is the greater.

1.26 Grass Seeding**1.26.1 Herbicide Application**

- Type: Suitable for suppressing perennial weeds and existing grass.
- Glyphosate and other controlled chemical pesticides will not be used under any circumstances.
- Suitable herbicide use to the instruction of a registered professional user.
- Timing: Allow fallow period before cultivation.
- Duration: As manufacturer's recommendation.

1.26.2 Seedbed cleaning before sowing

Operations: Herbicides as per registered professional user only.

1.26.3 Cultivation

- Compacted topsoil: Break up to full depth.
- Soil ameliorant/ Conditioner/ Fertilizer are to be used to boost late seeding only. Type to be used is to be agreed with the administering body depending on the time of year and the condition of the soil.
- Tilth: Reduce topsoil to a tilth suitable for blade grading.
 - Depth: 75 mm.
 - Particle size (maximum): 20 mm.
- Material brought to the surface: Remove stones and clay balls larger than 50 mm in any dimension, roots, tufts of grass, rubbish and debris.

1.26.4 Topsoiling

- Areas to be reinstated shall be top-soiled to a min. depth of 150mm.
- Quantity: Provide as necessary to make up any deficiency of topsoil existing on site and to complete the work.
- General: Do not use topsoil contaminated with subsoil, rubbish or other materials that are:
 - Corrosive, explosive or flammable;
 - Hazardous to human or animal life;
 - Detrimental to healthy plant growth.

1.26.5 Grading

- General appearance to be achieved: A fine graded finish to bring the ground to a uniform and even grade at the correct finished levels with smooth, flowing contours.
- Topsoil condition: Reasonably dry and workable.
- Contours: Smooth and flowing, with falls for adequate drainage.
- Hollows and ridges: Not permitted.
- Finished levels after settlement: 25 mm above adjoining paving, kerbs, manholes etc.
- Blade grading: May be used to adjust topsoil levels provided depth of topsoil is nowhere less than 150mm.
- Give notice: If required levels cannot be achieved by movement of existing soil.

1.26.6 Fertilizer for Seeded Areas

- Types: Apply both:
 - Superphosphate with a minimum of 18% water-soluble phosphoric acid.
 - A sulphate of ammonia with a minimum of 20% nitrogen.
- Application: Before final cultivation and three to five days before seeding/turfing.
- Coverage: Spread evenly, each type at 70 g/m², in transverse directions.

1.26.7 Final Cultivation

- Timing: After grading and fertilizing.
- Seed bed: Reduce to fine, firm tilth with good crumb structure.
- Depth: 50-100mm.
- Surface preparation: Rake to a true, even surface, friable and lightly firmed but not over compacted.
- Remove surface stones/earth clods exceeding:
 - Pastoral areas: 50mm.
 - Fine lawn areas: 10mm.
- Adjacent levels: Extend cultivation into existing adjacent grassed areas sufficient to ensure full marrying in of levels.

1.26.8 Grass Seed

- All seeds shall carry appropriate certificates.
- Seed shall be purchased fresh for each growing season and seed purchased impervious sowing seasons is not to be used.
- Seed shall be stored under non-transparent wrapping, off the ground, in a dry, shaded place, in well ventilated conditions under cover and shall be protected from vermin and contamination until required for use.
- No seeding shall take place until the seedbed is completed. All seeding shall be carried out within the sowing season.

1.26.9 Sowing

- General: Establish good seed contact with the root zone.
- Method: To suit soil type, proposed usage, location and weather conditions during and after sowing.
- Distribution: 2 equal sowings at right angles to each other.
- Protection: fence off areas with suitable fencing to stop people or animals from trampling new growth.

1.26.10 Grass sowing season

Grass seed generally: April to June or August to November.

1.27 Cleanliness

After completion of all works remove all debris and waste material from site.

- Soil and arisings: Remove from hard surfaces and grassed areas.
- General: Leave the works in a clean tidy condition at completion and after any maintenance operations.

2.0 MAINTENANCE

The maintenance programme will be organised on the basis of specific **performance standards** which must be met by the contractor at all times and will be the basis on which this contract will be assessed. Along with these performance standards a monthly report sheet shall be filled out and returned each month. Details of the performance standards are outlined below.

Remove all noxious and undesirable weeds from the site. Weeds shall include: Ragwort, Himalayan Balsam, Giant hogweed & Japanese knotweed, Thistle, Dock, Common Barberry, Male Wild Hop and Spring Wild Oat, or any other noxious species identified by the Department of Environment. For the removal of certain species such as Japanese Knotweed a method statement is to be prepared and submitted to the Department of Environment.

Performance Standards and Maintenance Operations

2.1 Grassed Areas

2.1.1 Fine-Cut Grass Areas

Fine cut grass areas shall achieve an even cover of vegetation of uniform height and colour comprising predominantly of grass species. No more than 5% of the grass areas shall contain dicotyledonous (dicots) weeds, except clover. Grass cutting shall not be carried out during excessively wet or waterlogged conditions. Contractor to inform administrative authority if conditions are unsuitable.

Fine-Cut Mowing

Where practical fine grass areas shall be cut using a cylinder mower, otherwise a rotary mower shall be used. All grass clippings shall be collected and removed off-site after each cut.

Lawn grass cutting shall be carried out every 10-14 days during the growing season, (throughout the period of March to October), but will need to be adjusted according to season's weather conditions. Grass shall be kept at a maximum height of 50mm and minimum height of 35mm. A minimum of 24 cuts shall be carried out annually.

Weed Control

Lawn grass areas shall be treated using an approved selective Glyphosate-free herbicide according to a registered professional user and manufacturer's instructions. Areas of invasive and noxious species in the lawn or areas, shall be mechanically removed or spot sprayed by a registered professional user.

Fertilizer

Approved fertilizer shall be applied 2no. times per year to lawn areas if required due to poor grass growth / establishment or yellowing. Spring fertilizer application of NPK ratio 9:7:7 shall be applied in May of each year and Autumn/Winter fertiliser of NPK ratio 3:12:12 shall be applied in October of each year to all fine cut grass areas.

2.1.2 Amenity Grass Areas

Amenity grass areas shall achieve an even cover of vegetation of uniform height and colour comprising predominantly of grass species. Unless otherwise agreed with the landscape architect no more than 15% of the grass areas shall contain dicotyledonous (dicots) weeds, except clover. Grass cutting shall not be carried out during excessively wet or waterlogged conditions. Contractor to inform administrative authority if conditions are unsuitable.

Amenity Grass Mowing

Where practical grass areas shall be cut using a cylinder mower, otherwise a rotary mower shall be used. Unless excessive or unsightly, or likely to cause a nuisance or damage to the sward, arisings shall be spread evenly over sward areas collected.

Lawn grass cutting shall be carried out every 10-14 days during the growing season, (throughout the period of March to October), but will need to be adjusted according to season's weather conditions. Grass shall be kept at a maximum height of 75mm and minimum height of 35mm. A minimum of 24 cuts shall be carried out annually.

Weed Control

Areas of invasive and noxious species in lawns, shall be mechanically removed. Glyphosate and other chemical pesticides will not be used under any circumstances unless otherwise instructed by a registered professional user. Weed infestations shall be reviewed in the context of the aesthetic and amenity functioning of the grass and if necessary controlled or eradicated.

Fertilizer

Approved fertilizer shall be applied 2no. times per year to lawn areas if required due to poor grass growth / establishment or yellowing. Spring fertilizer application of NPK ratio 9:7:7 shall be applied in May of each year and Autumn/Winter fertiliser of NPK ratio 3:12:12 shall be applied in October of each year to all fine cut grass areas.

2.1.4 Edging and Strimming

Grass edges along pathways, planting borders, roadways, trees, lampposts, signs and any other obstacle shall be kept neat and tidy at all times.

Between the months of March and October inclusive edging shall be carried out to all areas of grass abutting isolated/ specimen trees or shrub borders or mulch circles. These areas shall be maintained using a half moon tool or similar to maintain straight or curved defined line and shall be carried out a minimum of 2 - 3 times per year.

Mowing strips against permanent obstacles shall be a max. width of 150mm and shall be maintained using a hand strimmer. Large areas of desiccated/ burnt off grass are not permitted. Strimming shall be carried out a min. of 12 times per year.

Grass clipping and all arisings shall be swept up and removed off site.

2.1.5 Spring Bulbs in Grassed Areas

Only cut grassed areas populated by spring bulbs after the leaves of the bulbs have died down and/or yellowed completely. Initially reduce height by one third, followed by a 2-3 stage further reduction over two weeks to achieve desired grass height.

2.1.6 Failed areas

Areas of grass which fail or are damaged or worn shall be reinstated by re-turfing or re-seeding in accordance with the original specification.

2.2 Shrub Planting

Shrub areas shall be kept litter and weed free, particularly of perennial weeds. Healthy growth shall be maintained to cover as much as possible of the planting area and allowing the individual plants to achieve as near as possible their natural form. With the exception of hedges, boxing or pruning to shapes is prohibited. Plants shall be contained within designed planting areas and pruned to avoid obstructing pathways or sightlines. Climbers are to be pruned and tied into trellises as required, with two main inspections annually to check trellis system is intact and anchor points are secure.

2.3 Pruning

In general pruning shall be done only to enhance natural growth. Dead, damaged and diseased portions of the plant will be removed. All cuts shall be flush and clean, leaving no stubs or tearing of bark. All major pruning shall be done following flowering or during plant's dormant season. Emergency or minor pruning shall be done when needed.

Pruning shall be carried out to maintain proper size in relationship to adjacent plantings and intended function. Remedial attention and repair to shrubs shall be provided as appropriate by season or in response to incidental damage.

Groundcover plants shall be pruned as required to restrain perimeter growth to within planting bed areas where adjacent to walks and curbs. Tip prune selected branches of low growing shrub or groundcover masses to maintain even overall heights and promote fullness.

Certain plants, such as Cornus spp. will require heavy annual pruning in order to maintain healthy colourful stems and healthy leaves. All arising's from pruning shall be removed of site.

2.4 Weed Control

Planting beds shall be maintained relatively weed free (no more than 10% of weed cover at maximum) by hand weeding or spot spraying any emergent weeds during the growing season with Glyphosate-free herbicide or approved equivalent. Saplings shall be removed from all planting areas on emergence or immediately after to prevent establishment.

Specific weed control operations shall be carried out a min of 9no. times per year, however it will be the contractor's duty to control weeds by hand weeding or other accepted method if weed cover exceeds 10% of the planting area.

2.5 Mulching

Shrub beds shall contain a min. depth of 50mm bark mulch throughout the year. Contractor to top-up as 2 times per year or as appropriate to maintain depth. Mulch is not required in areas where plant foliage completely covers the soil surface, such that the soil is not visible through the foliage. The contractor shall spot treat to remove emergent weeds as specified above but do not cultivate or incorporate the mulch into the soil. Any mulch outside of designated planting areas shall be returned to the planter on a weekly basis.

Mulch shall be uniform in colour and appearance, and free of leaves, sticks, or trash. Mulch may be chipped or shredded wood, bark. When replacing existing mulch, use a mulch product that is similar in appearance to that already at the site.

2.6 Tree Planting Care

Trees shall be maintained in a healthy, vigorous growing condition with a well-shaped framework for future growth.

2.7 New Tree Planting

Spring and autumn of each year during the maintenance period the trees, double-stakes, rabbit guards and ties shall be checked and adjusted, the soil firmed, any dead wood removed back to healthy tissue and mulch adjusted to original levels. Any broken stakes or ties evident throughout the maintenance period shall be replaced.

A 1m-diameter mulch circle/square shall be maintained at the base of each tree located in open grass areas or grass verges. Top up bark mulch to 75mm where required and make good any mulch mats.

During the first growing season all standard trees / semi-mature trees shall be watered at least five times during the growing season - in April, May, June, July and August unless otherwise directed by the Landscape Architect. During the second growing season trees will be kept well watered, particularly during June, July and August.

The edge of the mulch circle shall be maintained in a neat and tidy condition as above.

The surface of all planting pits is to be kept free of weeds during the maintenance period by mechanical weeding of annual weeds and perennial weeds - to be carried out on three visits during the growing season.

2.9. Tree Stakes and Ties

Check tree stakes and ties on each maintenance visit. Repair, strengthen and adjust (loosen / tighten) to ensure optimum functioning and trees not being damaged by poor fixings. If trees no longer require stake / tie remove. Prior to handover, check all tree stakes and ties and remove those no longer required.

2.8 Woodland/Scrub Area Management

Woodland areas specified shall be maintained in a healthy, vigorous condition and free from litter and noxious weeds throughout the year.

Certain areas of woodland may require thinning over the 5-year period. These areas shall be thinned by no more than 10%, removing only the weaker tree specimens. Thinning shall be carried out as directed onsite by administrative authority.

Weed control around trees bases and in shrub areas will be achieved by mulches and mulch top ups only. Contractor to ensure that no damage is caused to trees by herbicide application.

Areas of natural scrub as indicated on the maintenance plans shall be contained by trimming back once per year. The contractor shall control noxious weeds. This shall be carried out 2no. times per annum.

All clearance operations within woodland and scrub areas shall be carried out outside of the bird-nesting season to preserve the bird life in the area. This season extends from the 1st March to 31st August.

2.10 Litter Clearance/Pick-up

The contractor shall maintain all areas free from litter. This shall mean the removal of all extraneous litter, rubbish and any other debris from all areas, which will include grass areas, planted areas, carparks, footpaths as well as woodlands and tree canopies.

Notwithstanding the above it is expected that the contractor and his staff shall take sufficient pride in the appearance of the site and that they would pick up all visible litter during every site visit.

In addition to removal of litter from footpaths, planted areas, etc., the contractor shall make provision for the immediate (within 1 days of notification) arrangement for collection and removal of all extraneous matter which has been deliberately been deposited on site by persons known or unknown (fly-tipping).

2.11 Replacements

Any tree, hedge or shrub that is removed, uprooted, destroyed or becomes seriously damaged, defective, diseased, or dead shall be replaced in the same location with another plant of the same species and size as that originally planted within the defect period after planting. All such replacements shall be carried out in the first available planting season after the requirement to do so is recognised.

Tree planting detail

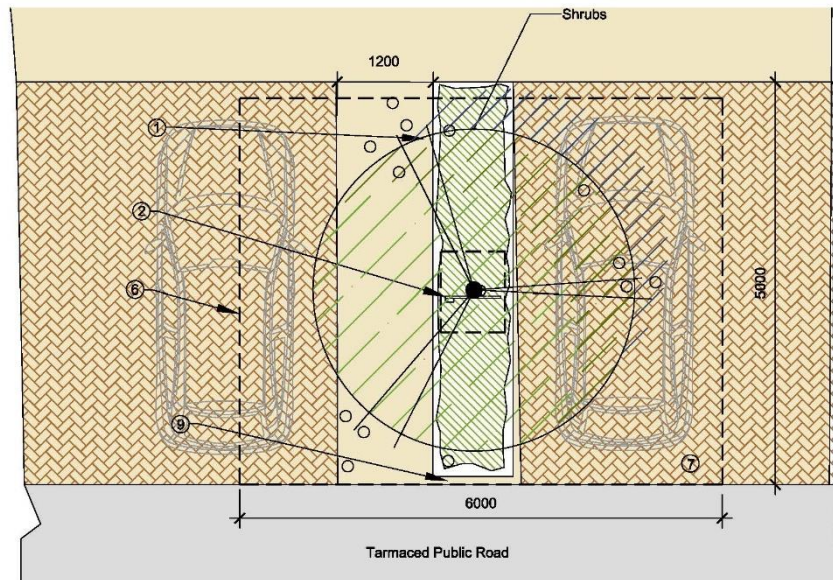

VO1: Street Tree Pit Detail – Plan

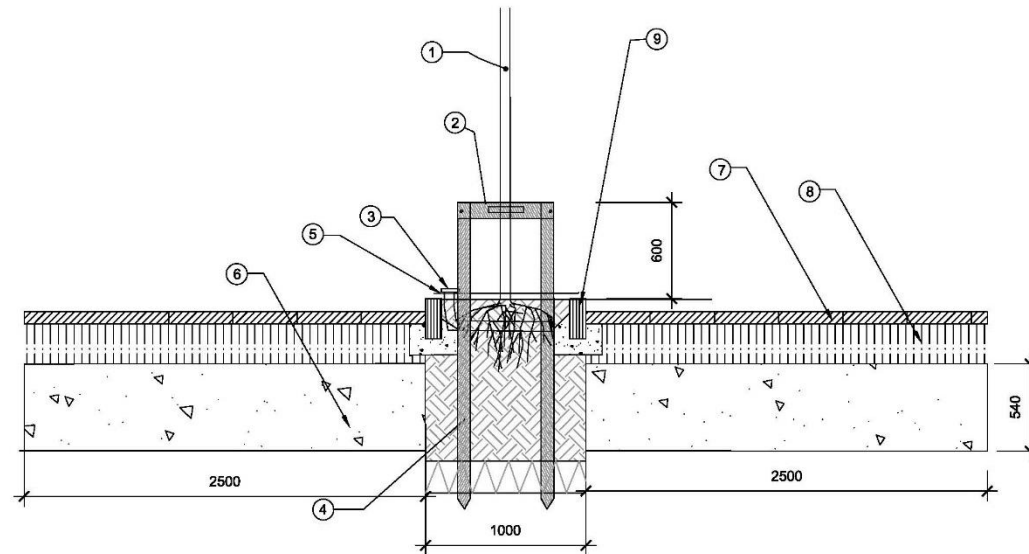

VO1: Street Tree Pit Detail – Section

NOTES

- ① Tree to have a clear stem height of 2000mm.
- ② 2no. 75mm diameter stakes pressure treated driven 1300mm below ground 600mm above ground with specified biodegradable adjustable tie affixed to tree & stake.
- ③ 6cm diameter perforated flexible plastic drainage pipe positioned as shown over rootball with one end open to surface to facilitate watering.
- ④ Pits to be size 80x125x100cm. Remove the full depth of topsoil and set aside for reuse. Scarify sides, break up base of pit to a depth of 200mm and incorporate a soil ameliorant into base. Back fill pit with topsoil mixed with soil ameliorants in 150mm firmed-in layers. All planting to receive a minimum of 25lit water per m2 immediately after planting.
- ⑤ 50mm bark mulch in 80cm dia circle to base of trunk.
- ⑥ 16m3 area root zone under permeable paving for parking bays, made up of 50% 70-100mm aggregate sizes, 30% multipurpose topsoil and 20% grit (20mm down).
- ⑦ Permeable parking paving to engineers spec.
- ⑧ Sub base to parking to engineers spec.
- ⑨ Kerb to engineers spec.

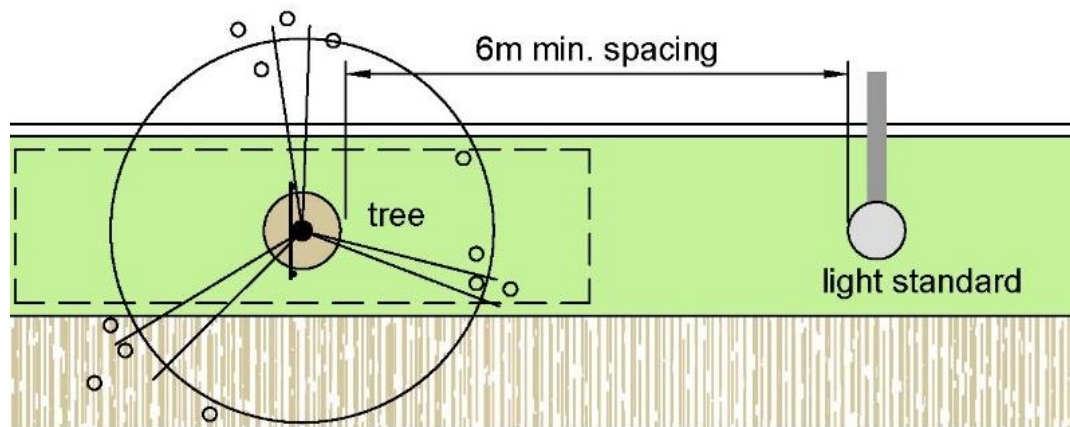

VO2: Street Tree Pit and Light Standard Detail – Plan

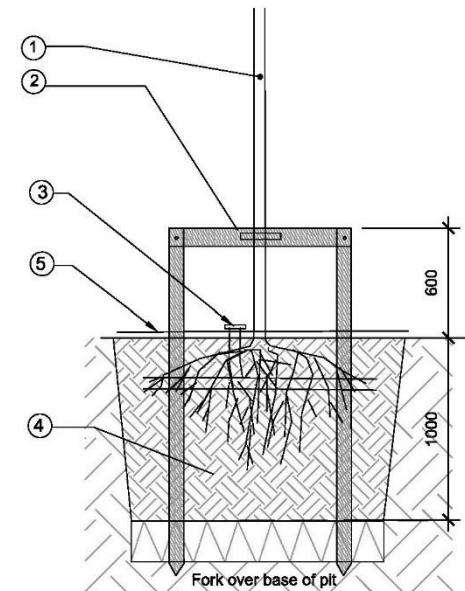

VO2: Street Tree Pit Detail – Section

NOTES

- ① To have a clear stem height of 2000mm.
- ② 2no. 75mm diameter stakes pressure treated driven 1300mm below ground 600mm above ground with specified biodegradable adjustable tie affixed to tree & stake.
- ③ 6cm diameter perforated flexible plastic drainage pipe positioned as shown over rootball with one end open to surface to facilitate watering.
- ④ Pits to be size 1x1x1mm or 15cm wider than rootball which ever is greater. Remove the full depth of topsoil and set aside for reuse. Scarify sides, break up base of pit to a depth of 200mm and incorporate a soil ameliorant into base. Back fill pit with topsoil mixed with soil ameliorants in 150mm firmed-in layers. All planting to receive a minimum of 25lit water per m2 immediately after planting.
- ⑤ 50mm bark mulch in 80cm dia circle to base of trunk.

3.0 Maintenance Programme

This programme is a guideline only and times of operations may vary on approval by landscape architect.

ONGOING REQUIREMENTS:	JAN	FEB	MAR	APR	MAY	JUN	JUL	AUG	SEP	OCT	NOV	DEC
Lawn grass cutting (Min 24 cuts)		*	**	**	***	***	***	***	***	**	**	
Edging to lawn grass areas				*			*			*		
Rough Grass							*					
Fertiliser application to lawn grass areas.					*		*			*		
Hedge pruning/cutting					*			*			*	
Shrubs pruning and feeding				*		*			*			
Weed control of hedge and shrub planting areas		*	*	*	*	*	*	*	*	*	*	
Tree pruning											*	*
Removal of tree stakes (3-5yr)				*								
Mulch top-up to tree circles/ squares						*				*		
Weed control to tree mulch circles				*			*			*		
Weed control to shrubs & hedgerow				*			*			*		
Watering of new trees (or after 3 weeks of no rain)				*	*	*	*	*				
Trimming of scrub areas												*
Weed control of scrub areas				*					*			
Weed control to footpaths, cycle paths.				*								
Litter Clearance/pick up	***	***	***	***	***	***	***	***	***	***	***	***